



# Hi3559 V100 Professional 2K/4K Mobile Camera SoC

## Introduction

Hi3559 V100 is a new-generation MobileCam™ intelligent video processor provided by HiSilicon, a leading supplier in the global ultra-HD video technologies. The Hi3559 V100 processor is launched for the professional camera, high-end drone camera, extreme sports motion DV, 3D/VR camera, and high-end EDR product fields.

Hi3559 V100 uses the HiSilicon fifth-generation Hi-Lark high-performance video encoder, which supports simultaneous 4K@30 fps encoding and 1-channel 1080p@30 fps small-stream encoding. Besides, it can also record high-frame-rate videos such as 2K@60 fps, 1080p@120 fps, and 720p@240 fps.

Hi3559 V100 uses the HiSilicon fourth-generation Hi-ISP high-performance graphics processor and adopts the latest 3A, 3DNR, and HDR technologies to achieve professional picture effect. Hi3559 V100 supports dual sensor inputs and maximum 16-megapixel and 8-megapixel video processing to flexibly support the service scenarios that required dual-channel recording, such as the 3D/VR camera. Hi3559 V100 integrates high-speed transfer and storage USB 3.0 and PCIe 2.0 interfaces that transfer and store 1080P30 RAW data to achieve the effect of a professional camera.

Hi3559 V100 integrates the high-performance dual-core CPU (A17+A7). Apart from the video encoding and ISP processing functions, Hi3559 V100 also supports intelligent functions, such as EIS and optical flow hovering. Hi3559 V100 adopts the 28 nm HPC+ advanced manufacturing process and the 10 mm x 10 mm (0.39 in. x 0.39 in.) FC-CSP package. These features enable Hi3559 V100 to continuously lead the industry in high picture quality, low power consumption, and miniaturization.

## Application Scenario

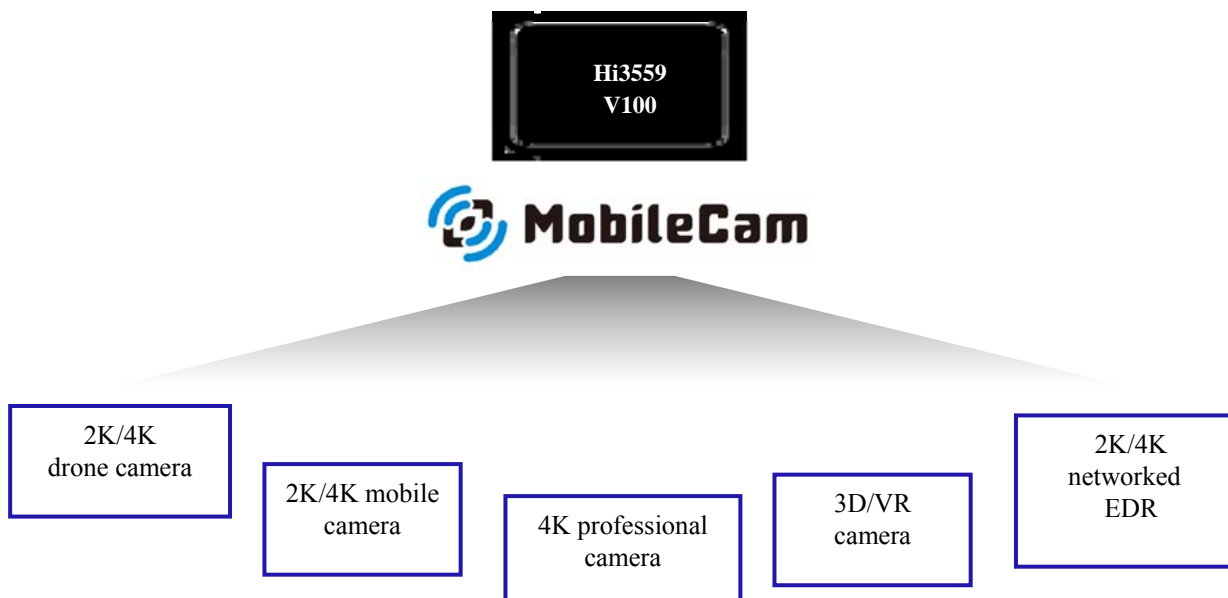

## Key Specifications

- **4K30/1440P60 H.265 Encoding**  
4K@30 fps+1080p@30 fps or 1440p@60 fps+1080p@30 fps H.265 encoding
- **Dual-Sensor Inputs**  
2K x 2K@30 fps 3D or 3K x 3K@15 fps dual-fisheye inputs
- **6-DoF DIS**
- **High-Speed Memory Interfaces**  
USB 3.0 or PCIe 2.0 high-speed interface
- **RAW Video Output**  
Professional 1080p@30 fps video RAW output
- **Low Power Consumption**  
1.25 W typical power consumption in the 4K@30 fps+1080p@30 fps H.265 encoding scenario
- **Miniaturization Package**  
10 mm x 10 mm (0.39 in. x 0.39 in.) package



# Hi3559 V100 Professional 2K/4K Mobile Camera SoC

## Major Specifications

### Processor Core

- 1.25 GHz A17 core, supporting 32 KB I-cache, 32 KB D-cache, and 256 KB L2 cache
- 800 MHz A7 core, supporting 32 KB I-cache, 32 KB D-cache, and 128 KB L2 cache
- Neon acceleration, integrated FPU
- Linux+Huawei LiteOS dual-system heterogeneous architecture

### Video Encoding

- H.264 BP/MP/HP
- H.265 Main Profile
- I/P/B frame H.264/H.265 encoding, supporting the dual-P-frame reference mode
- MJPEG/JPEG Baseline encoding

### Video Encoding Performance

- Maximum 16-megapixel (4608 x 3456) resolution for H.264/H.265 encoding
- H.264/H.265 multi-stream real-time encoding capability of 4K@30 fps+1080p@30 fps+4K@2 fps snapshot
- Maximum 16-megapixel@15 fps JPEG snapshot performance
- 2 kbit/s to 100 Mbit/s CBR or VBR control
- Encoding frame rate ranging from 1 fps to 240 fps
- Encoding of eight ROIs

### Intelligent Video Analysis

- Integrated intelligent analysis acceleration engine, which allows customers to develop intelligent applications targeted for the mobile camera product, such as optical flow hovering and target tracking

### Video and Graphics Processing

- 3DNR, image enhancement, and DCI
- Anti-flicker for output videos and graphics
- 1/30x to 16x video scaling
- Horizontal seamless stitching of 2-channel videos
- 1/2x to 2x graphics scaling
- OSD overlaying of eight regions before encoding
- Video graphics overlaying of two layers (video layer and graphics layer)

### ISP

- 2-channel independent ISP processing
- Adjustable 3A functions (AE, AWB, and AF)
- FPN removal
- Highlight suppression, backlight compensation, gamma correction, and color enhancement
- DPC, NR, and DIS
- Anti-fog
- LDC and fisheye correction
- Picture rotation by 90° or 270°
- Picture mirror and flip
- Sensor built-in WDR, 4F/3F/2F frame-based/line-based WDR, and local tone mapping. The second channel of ISP

processing supports only sensor built-in WDR, 2F frame-based/line-based WDR, and local tone mapping.

- ISP tuning tools for the PC

### Audio Encoding/Decoding

- Voice encoding/decoding complying with multiple protocols by using software
- MP3 or AAC audio encoding format
- Audio 3A functions (AEC, ANR, and ALC)

### Security Engine

- AES, DES, and 3DES encryption and decryption algorithms implemented by using hardware
- RSA1024/2048/4096 signature verification algorithm implemented by using hardware
- Hash-SHA1/256 and HMAC\_SHA1/256 tamper proofing algorithms implemented by using hardware
- Integrated 512-bit OTP storage space and hardware random number generator

### Video Interfaces

- VI Interfaces
  - Two sensor inputs. The maximum resolution for the main channel is 16 megapixels (4608 x 3456), and the maximum resolution for the second input is 8 megapixels (4096 x 2160).
  - 8-/10-/12-/14-bit RGB Bayer DC timing VI, at most 150 MHz clock frequency
  - BT.601, BT.656, and BT.1120 VI interfaces
  - Maximum 12-lane MIPI/LVDS/sub-LVDS/HiSPi interface for the main channel
  - Maximum 4-lane MIPI/LVDS/sub-LVDS/HiSPi interface for the second sensor interface
  - Compatibility with mainstream HD CMOS sensors provided by Sony, Aptina, OmniVision, and Panasonic
  - Compatibility with the electrical specifications of parallel and differential interfaces of various sensors
  - Programmable sensor clock output
- VO interfaces
  - One PAL/NTSC output for automatic load detection
  - One BT.1120/BT.656 VO interface for connecting to an external HDMI or SDI, 1080p@60 fps output at most
  - LCD output

### Audio Interfaces

- Integrated audio codec supporting 16-bit audio inputs and outputs
- I<sup>2</sup>S interface for connecting to the external audio codec
- Dual-channel differential MIC inputs for reducing background noises

### Peripheral Interfaces

- POR
- External reset input
- Internal RTC
- Integrated 3-channel LSADC
- Five UART interfaces



# Hi3559 V100 Professional 2K/4K Mobile Camera SoC

- IR interface, I<sup>2</sup>C interface, SSP master interface, and GPIO interface
- Eight PWM interfaces (four independent interfaces and four ones multiplexed with other pins)
- Two SD 3.0/SDIO 3.0 interfaces, supporting SDXC
- One USB 3.0/USB 2.0 host/device port
- One PCIe 2.0 interface in master/slave mode

- 4-/8-/24-/40-/64-bit ECC
- Components with 8 GB or larger capacity
- Booting from the SPI NOR flash, SPI NAND flash, or NAND flash
- Booting from an eMMC or PCIe

### External Memory Interfaces

- DDR4/DDR3/DDR3L/LPDDR3 interface
  - 32-bit LPDDR3
  - 32-bit DDR4/DDR3/DDR3L
  - Maximum capacity of 1024 MB for a 16-bit DDR SDRAM
  - Maximum total capacity of 2048 MB for two 16-bit DDR SDRAMs
- SPI NOR flash interface
  - 1-/2-/4-line mode
  - 3-byte or 4-byte address mode
  - Maximum capacity of 32 MB
- SPI NAND flash interface
  - Maximum capacity of 512 MB
- eMMC 5.0 interface
  - Maximum capacity of 2 TB
- NAND flash interface
  - 8-bit data width
  - SLC or MLC

### SDK

- Dedicated SDK for the consumer mobile camera
- High-performance H.265 iOS/Android decoding library

### Physical Specifications

- Power consumption
  - Typical power consumption of 1.25 W
  - Multi-level power saving mode
- Operating voltages
  - 0.9 V core voltage
  - 3.3 V I/O voltage and 3.8 V margin voltage
  - 1.2 V, 1.5 V, 1.35 V, and 1.2 V voltage for the DDR4, DDR3, DDR3L, and LPDDR3 SDRAM interface, respectively
- Package
  - RoHS, FC-CSP
  - Body size of 10 mm x 10 mm (0.39 in. x 0.39 in.)
  - Lead pitch of 0.4 mm (0.02 in.)

## Functional Block Diagram

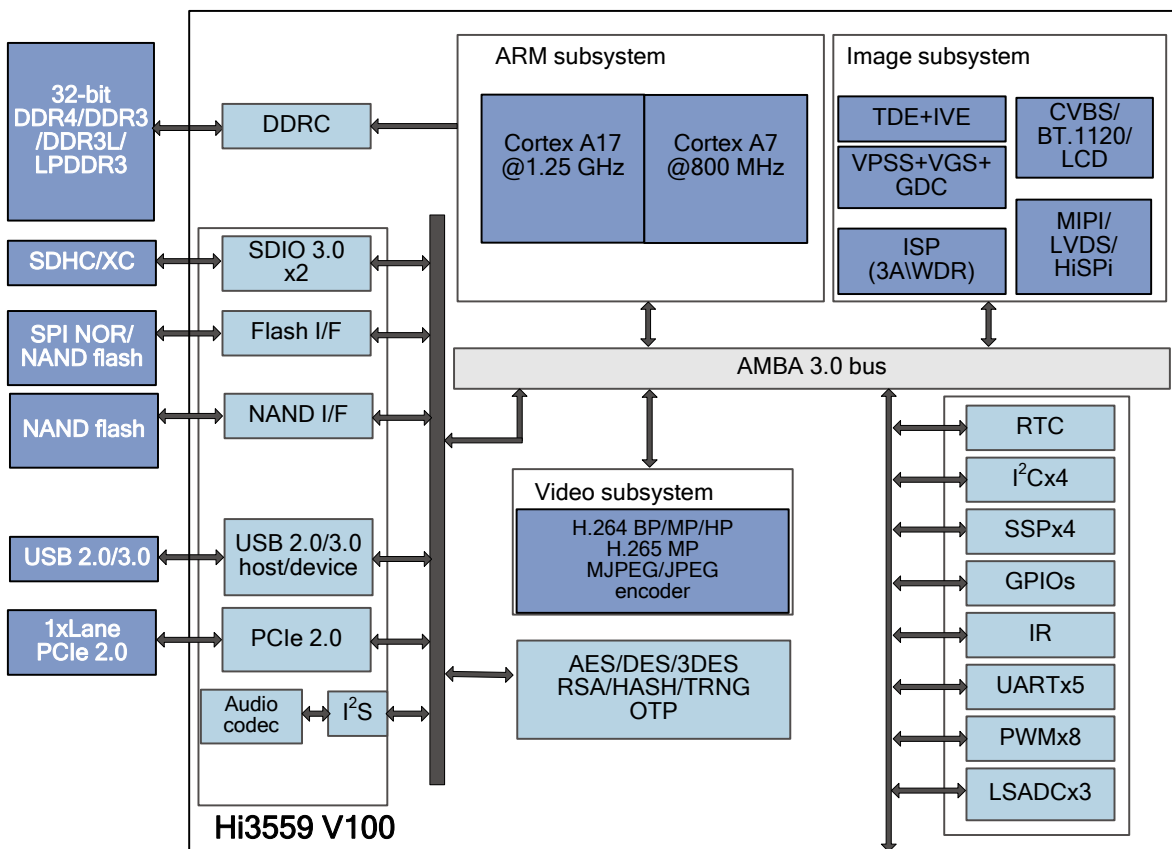



# Hi3559 V100 Professional 2K/4K Mobile Camera SoC

## Hi3559 V100 Motion Camera and Professional Camera Solution

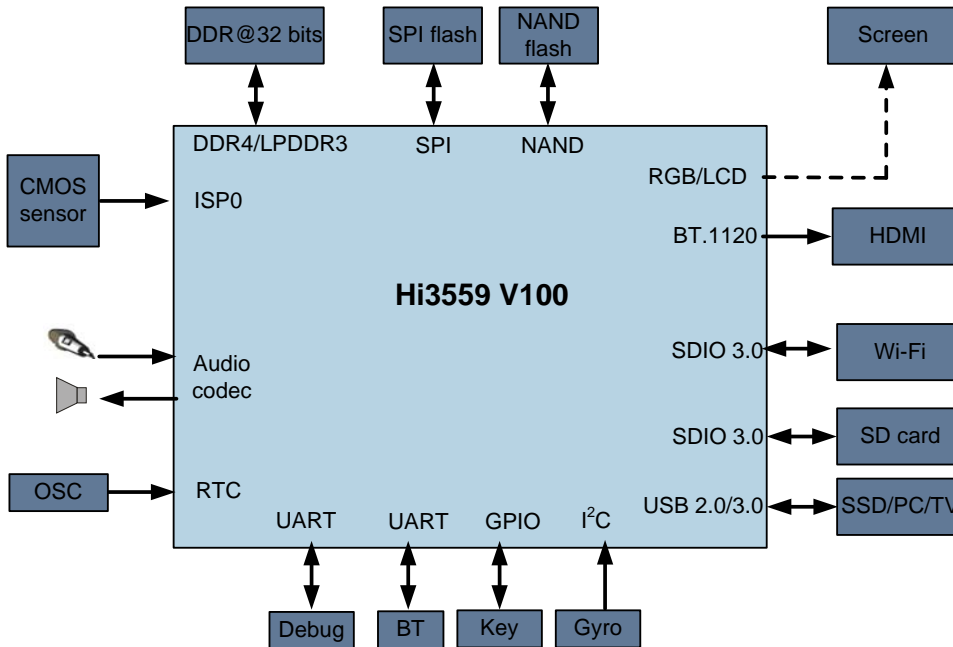

- Supports 6-DoF 4K@30 fps video DIS in the gyro auxiliary information.
- Supports HDR photographing.
- Supports RAW video output.
- Support low-power LPDDR3 and DDR4.
- Supports 2x SDIO 3.0, the extended low-power Wi-Fi module, and the external SDXC card.
- Supports dual MICs and provides advanced dual-MIC NR algorithms.

## Hi3559 V100 3D/VR Camera Solution

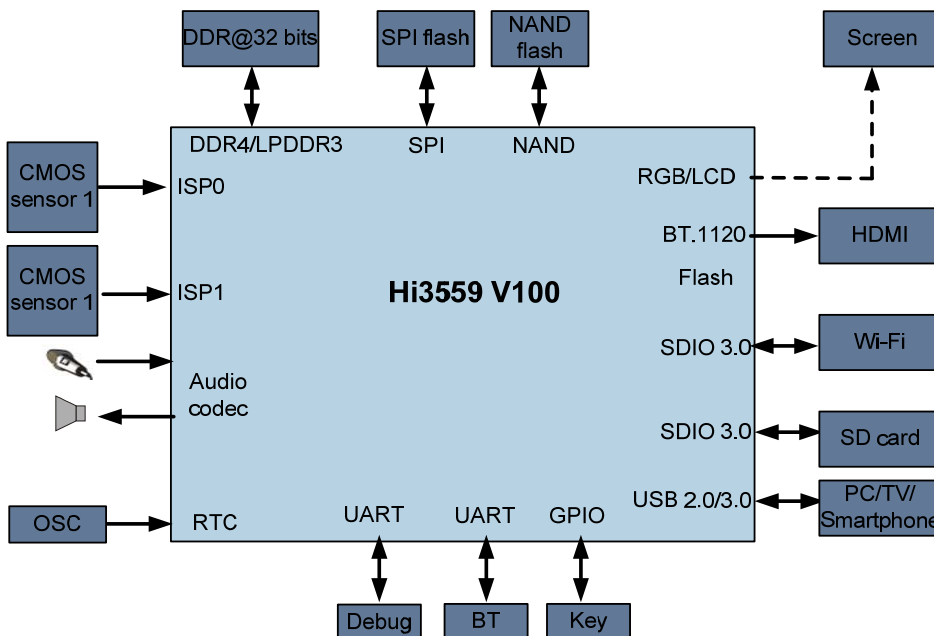

- Supports dual-channel 3K x 3K@15 fps or 2K x 2K@30 fps input and professional dual-channel ISP processing.
- Supports HDR photographing.
- Support low-power LPDDR3 and DDR4.
- Supports 2x SDIO 3.0, the extended low-power Wi-Fi module, and the external SDXC card.
- Supports dual MICs and provides advanced dual-MIC NR algorithms.



# Hi3559 V100 Professional 2K/4K Mobile Camera SoC

## Hi3559 V100 Drone Camera Solution

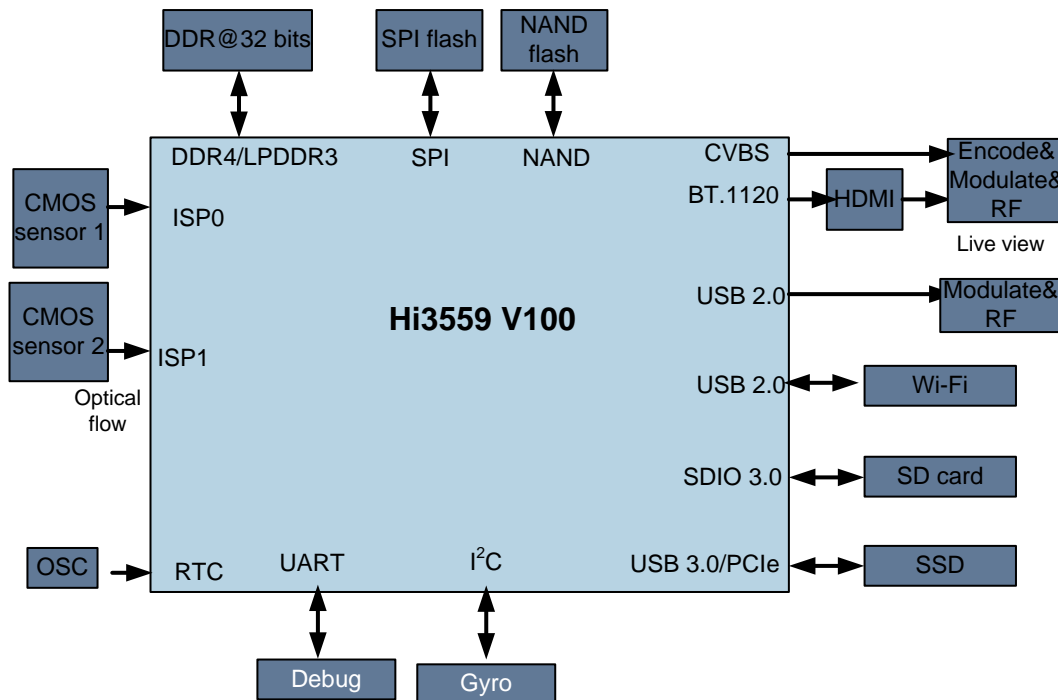

- Supports 6-DoF 4K@30 fps video DIS in the gyro auxiliary information.
- Supports HDR photographing.
- Supports RAW video output.
- Support low-power LPDDR3 and DDR4.
- Support the input of the second-channel sensor for optical flow hovering.
- Support low-power LPDDR3 and DDR4.
- Supports CVBS-to-HDMI or BT.1120-to-HDMI and outputs videos in real time for picture transmission.
- Allows the second-channel low-delay stream to be output over the USB 2.0 port for picture transmission.