



Hi3516A Professional HD IP Camera SoC

Key Specifications

Processor Core

- A7@600 MHz, 32 KB I-cache, 32 KB D-cache/128 KB L2 cache
- Neon acceleration, integrated FPU

Video Encoding

- H.264 BP/MP/HP
- H.265 main profile
- MJPEG/JPEG baseline encoding

Video Encoding Performance

- A maximum of 5-megapixel resolution for H.264/H.265 encoding
- Real-time H.264/H.265 encoding of multiple streams:
 - 1080p@30 fps+720p@30 fps+VGA@30 fps
 - 1080p@60 fps+VGA@30 fps
 - 5-megapixel@30 fps+VGA@30 fps
- JPEG snapshot at 5-megapixel@8 fps
- Supporting the CBR/VBR bit rate control mode, ranging from 16 kbit/s to 40 Mbit/s
- Encoding frame rate ranging from 1/16 fps to 60 fps
- Encoding of eight ROIs

Intelligent Video Analysis

- Integrated IVE, supporting various intelligent analysis applications such as motion detection, boundary security, vehicle license plate recognition, and video diagnosis

Video and Graphics Processing

- 3D denoising, image enhancement, and dynamic contrast enhancement
- Anti-flicker for output videos and graphics
- 1/15.99x to 16x video scaling
- 1/2x to 2x graphics scaling
- OSD overlay pre-processing for eight regions
- Video graphics overlaying of two layers (video layer and graphics layer)

ISP

- Adjustable 3A functions (AE, AWB, and AF)
- Noise reduction in FPN mode
- Highlight compensation, backlight compensation, gamma correction, and color enhancement
- Defect pixel correction, denoising, and digital image stabilizer
- Anti-fog
- Lens distortion correction
- Picture rotation by 90° or 270°
- Mirroring and flipping
- Digital WDR, frame base/line base WDR, and tone mapping
- ISP tuning tools for the PC

Audio Encoding/Decoding

- Voice encoding/decoding in compliance with multiple

protocols by using software

- G.711, ADPCM, and G.726 protocols
- AEC, ANR, and ALC

Security Engine

- Various encryption and decryption algorithms using hardware, such as AES, DES, and 3DES
- Digital watermark

Video Interfaces

- Input
 - 8-/10-/12-/14-bit RGB Bayer DC timing VI, a maximum of 150 MHz clock frequency
 - BT.601, BT.656 or BT.1120 VI interface
 - MIPI, LVDS/sub-LVDS, and HiSPI
 - Compatibility with mainstream HD CMOS sensors provided by Sony, Aptina, OmniVision, and Panasonic
 - Compatibility with the electrical specifications of parallel and differential interfaces of various sensors
 - Programmable sensor clock output
 - Maximum input resolution of 5 megapixels
- Output
 - One PAL/NTSC output for automatic load detection
 - One BT.1120/BT.656 VO interface for connecting to an external HDMI or SDI, up to 1080p@60 fps output

Audio Interfaces

- Integrated audio CODEC, supporting 16-bit audio inputs and outputs
- I²S interface for connecting to an external audio CODEC

Peripheral Interfaces

- POR
- One integrated high-precision RTC
- One dual-channel SAR ADC
- Four UART interfaces
- One IR interface, three I²C interfaces, four SPI master interfaces, 14 x 8 + 3 GPIO interfaces
- Eight PWM interfaces (four independent interfaces and four multiplexed with other pins)
- Two SDIO 3.0 interfaces, supporting SDXC
- One USB 2.0 host/device port
- RGMII/RMII in 100/1000 Mbit/s full-duplex or half-duplex mode, PHY clock output, and TSO network acceleration

External Memory Interfaces

- DDR3/3L SDRAM interface
 - One 32-bit DDR3/3L interface with the maximum frequency of 600 MHz (1.2 Gbit/s)
 - Maximum capacity of 4 Gbits for a 16-bit DDR
 - Maximum capacity of 8 Gbits for two 16-bit DDRs
- SPI NOR flash interface
 - 1-, 2-, or 4-wire mode
 - Maximum capacity of 32 MB
- SPI NAND flash interface
 - Maximum capacity of 4 Gbits
- NAND flash interface



Hi3516A Professional HD IP Camera SoC

- 8-bit data width
- SLC or MLC
- 1-, 4-, 8-, or 24-bit ECC
- Components with 8 GB capacity or larger
- Maximum capacity of 16 Gbits
- Booting from the SPI NOR flash, SPI Nand Flash or NAND flash

SDK

- Linux-3.4-based SDK
- High-performance H.264/H.265 PC decoding library

Physical Specifications

- Power consumption
 - 1.1 typical power consumption@1080p60
 - Multi-level power-saving mode
- Operating voltages
 - 1.1 V core voltage
 - 3.3 V I/O voltage and 3.8 V margin voltage
 - 1.35 V or 1.5 V DDR3/3L SDRAM interface voltage
- Package
 - Body size of 15 mm x 15 mm (0.59 in. x 0.59 in.), 0.65 mm (0.03 in.) ball pitch, TFBGA RoHS



Hi3516A Professional HD IP Camera SoC

Functional Block Diagram

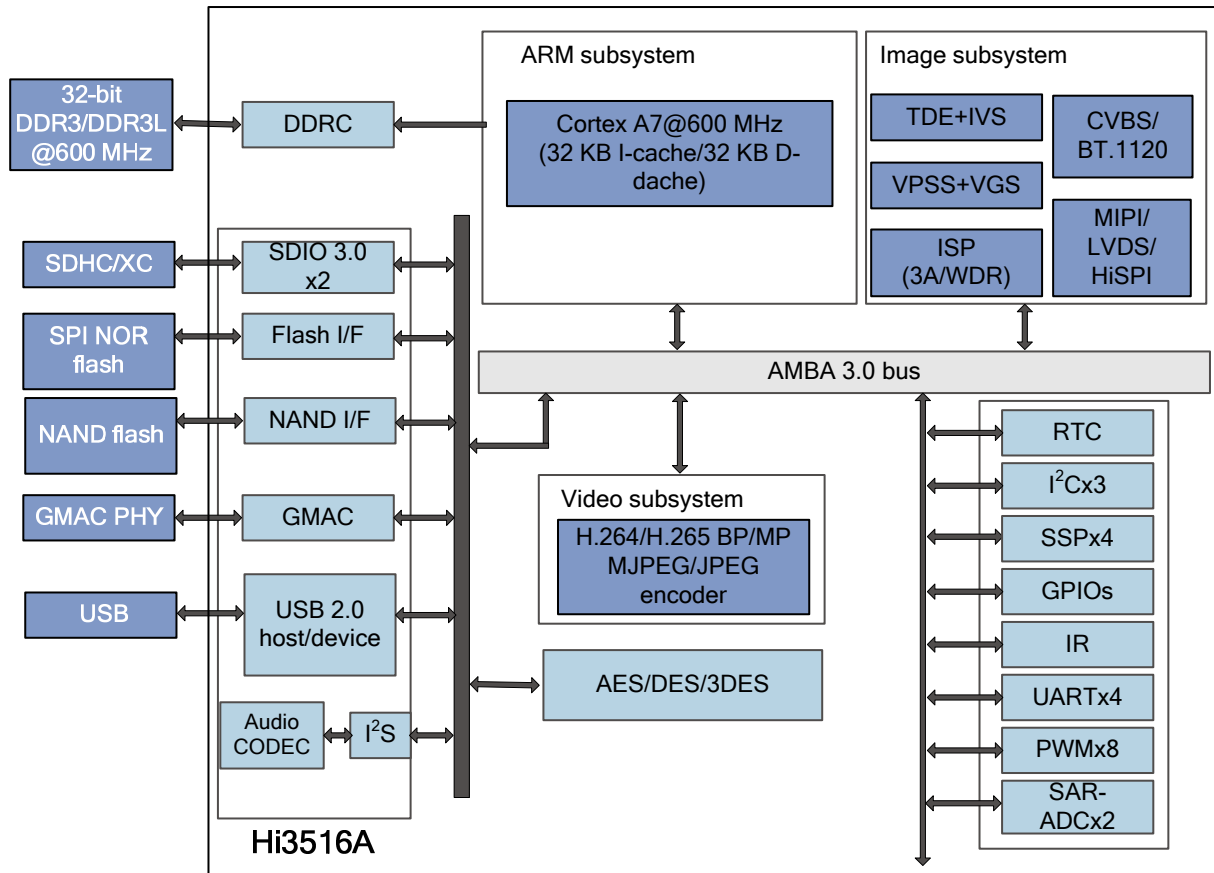

As a new-generation SoC designed for the HD IP camera, the Hi3516A integrates a new-generation ISP and adopts the latest H.265 compressed video encoder, advanced low-power technology, and low-power architecture design. These features help the Hi3516A keep the leading position in the aspects of low bit rate, high picture quality, and low power consumption. The Hi3516A supports 90° or 270° rotation and lens distortion correction, which meets requirements in various surveillance applications. It also fully supports 3A algorithms, which allow customers to design different types of IP cameras including the IP AF zoom module. The Hi3516A integrates the POR, RTC, and audio CODEC and supports various sensor levels and clock outputs, which significantly reduces the EBOM costs for the Hi3516A HD IP camera. Similar to other HiSilicon DVR and NVR SDKs, the Hi3516A SDK features high stability and ease of use, which allows rapid mass production and facilitates system layout of IP cameras, DVRs, and NVRs.

Hi3516A HD IP Camera Solution



Hi3516A Professional HD IP Camera SoC

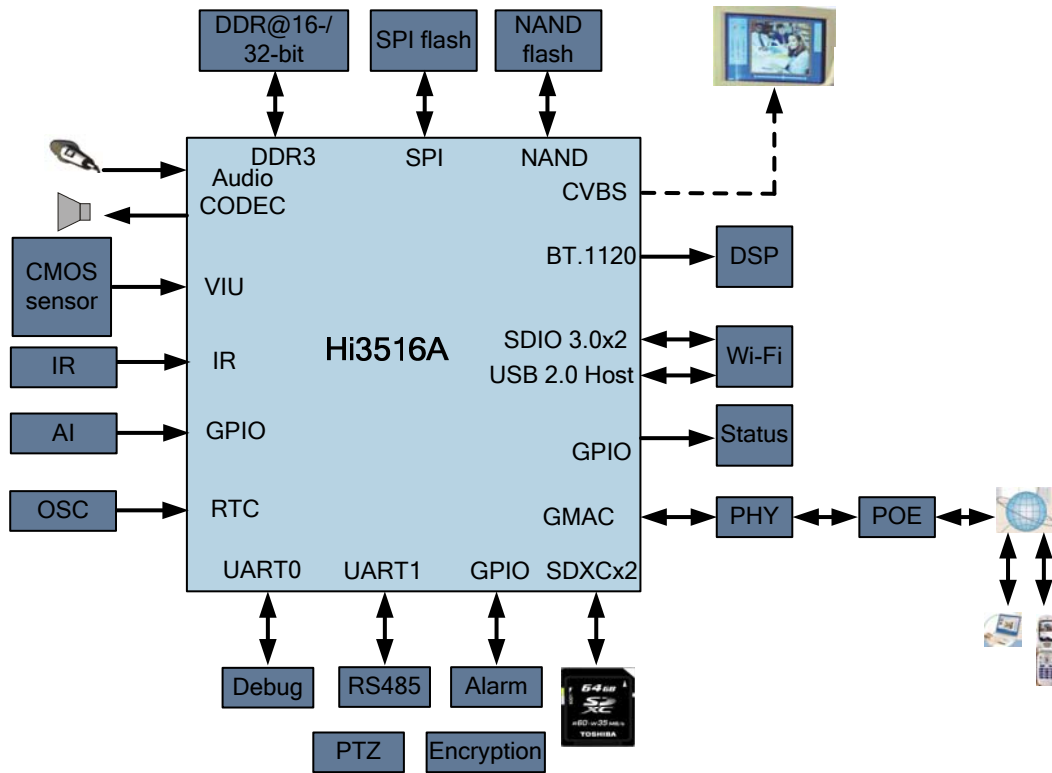

Acronyms and Abbreviations

3DES	triple data encryption standard
ABR	average bit rate
ADC	analog-to-digital converter
AE	automatic exposure
AEC	acoustic echo cancellation
AES	advanced encryption standard
AF	automatic focus
ALC	auto level control
ANR	audio noise reduction
AWB	automatic white balance
CBR	constant bit rate
CMOS	complementary metal-oxide semiconductor
CODEC	coder/decoder
DES	data encryption standard
DVR	digital video recorder
ECC	error correcting code
FPN	fixed pattern noise
FPU	floating point unit
GPIO	general-purpose input/output
HD	high definition
HDMI	high-definition multimedia interface
I ² C	inter-integrated circuit
I ² S	inter-IC sound
IR	infrared
ISP	image signal processor